

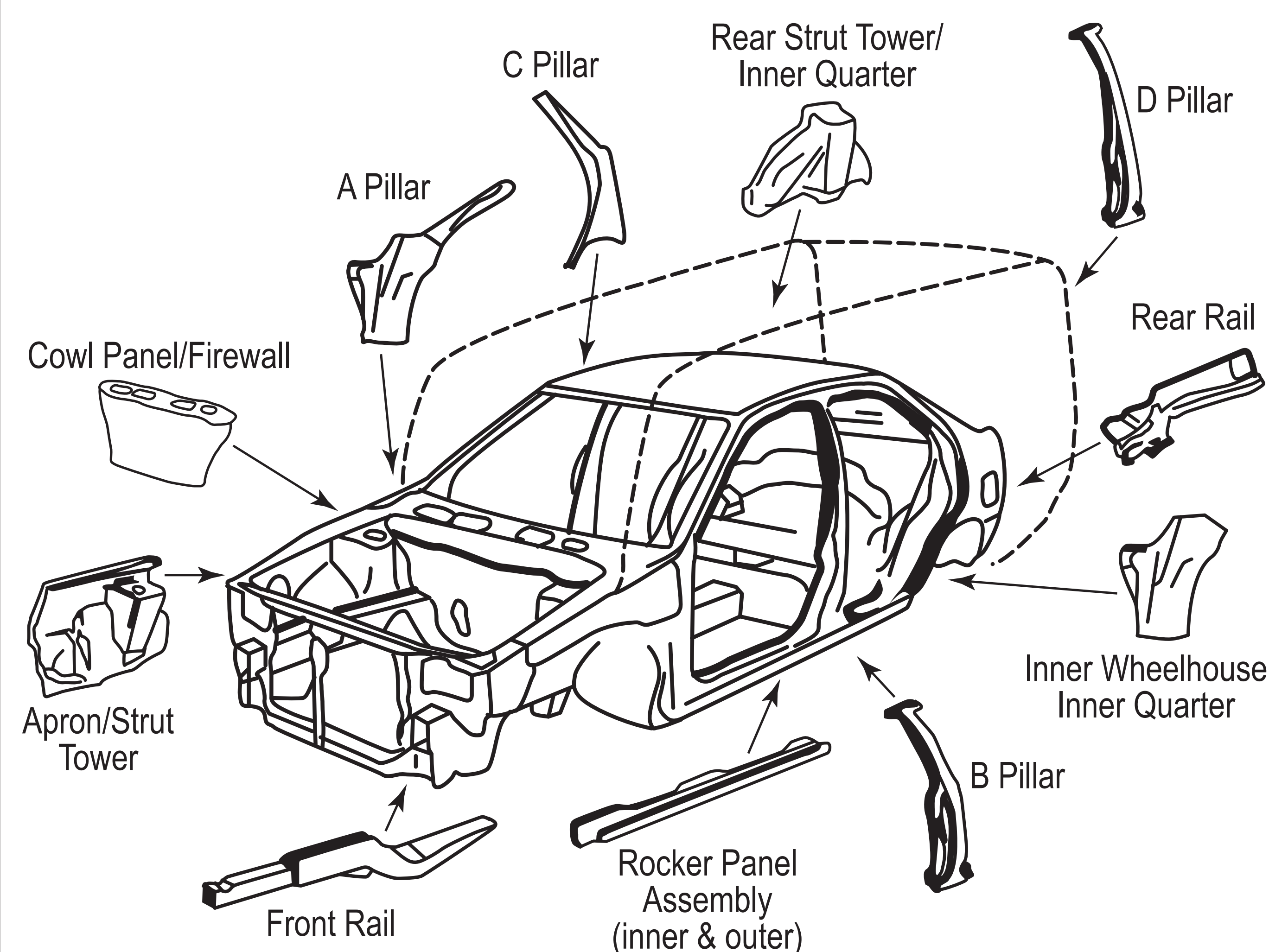

TYPICAL UNIBODY STRUCTURE

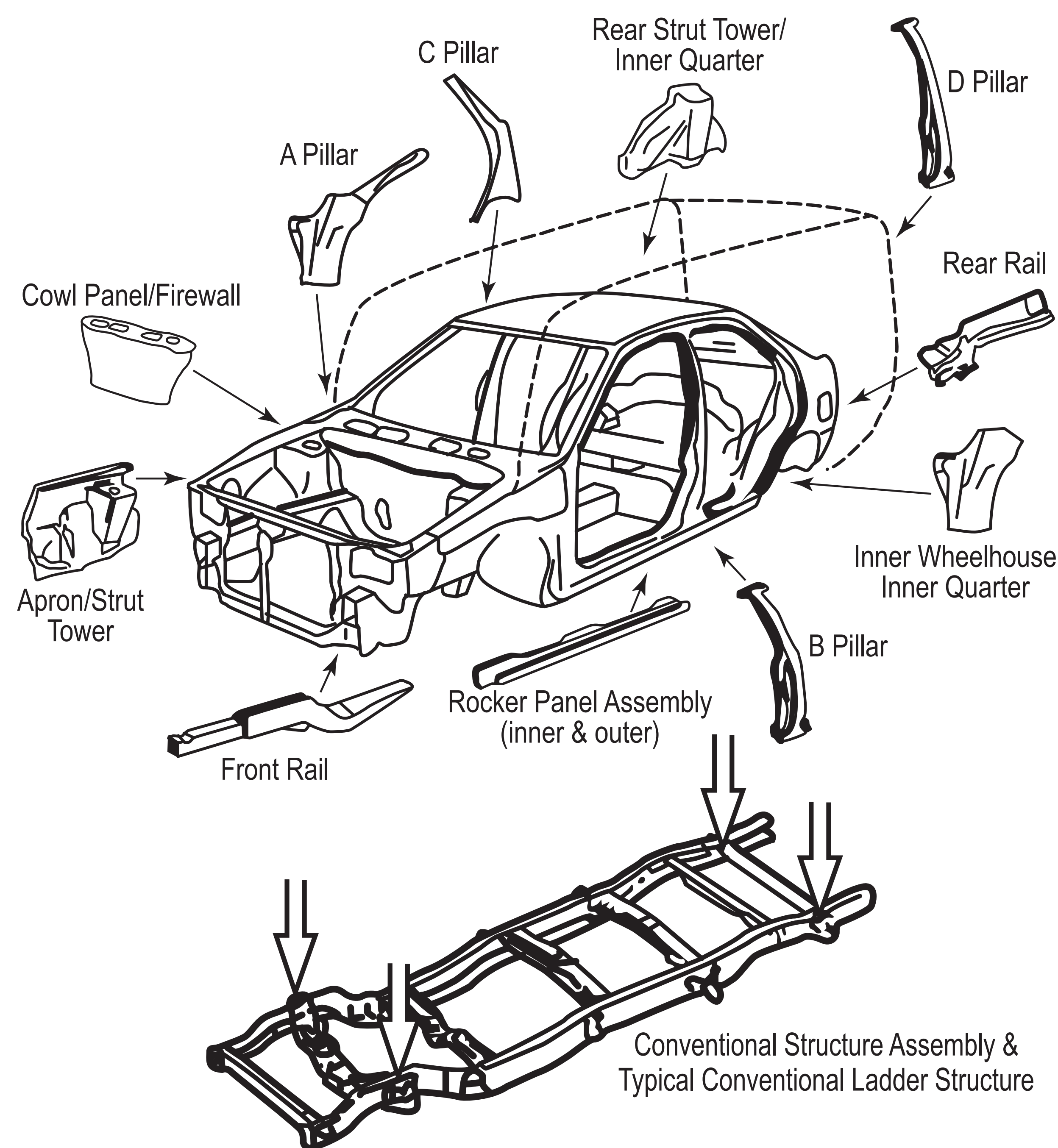

TYPICAL UNIBODY ON CONVENTIONAL STRUCTURE



TYPICAL CONVENTIONAL PERIMETER STRUCTURE

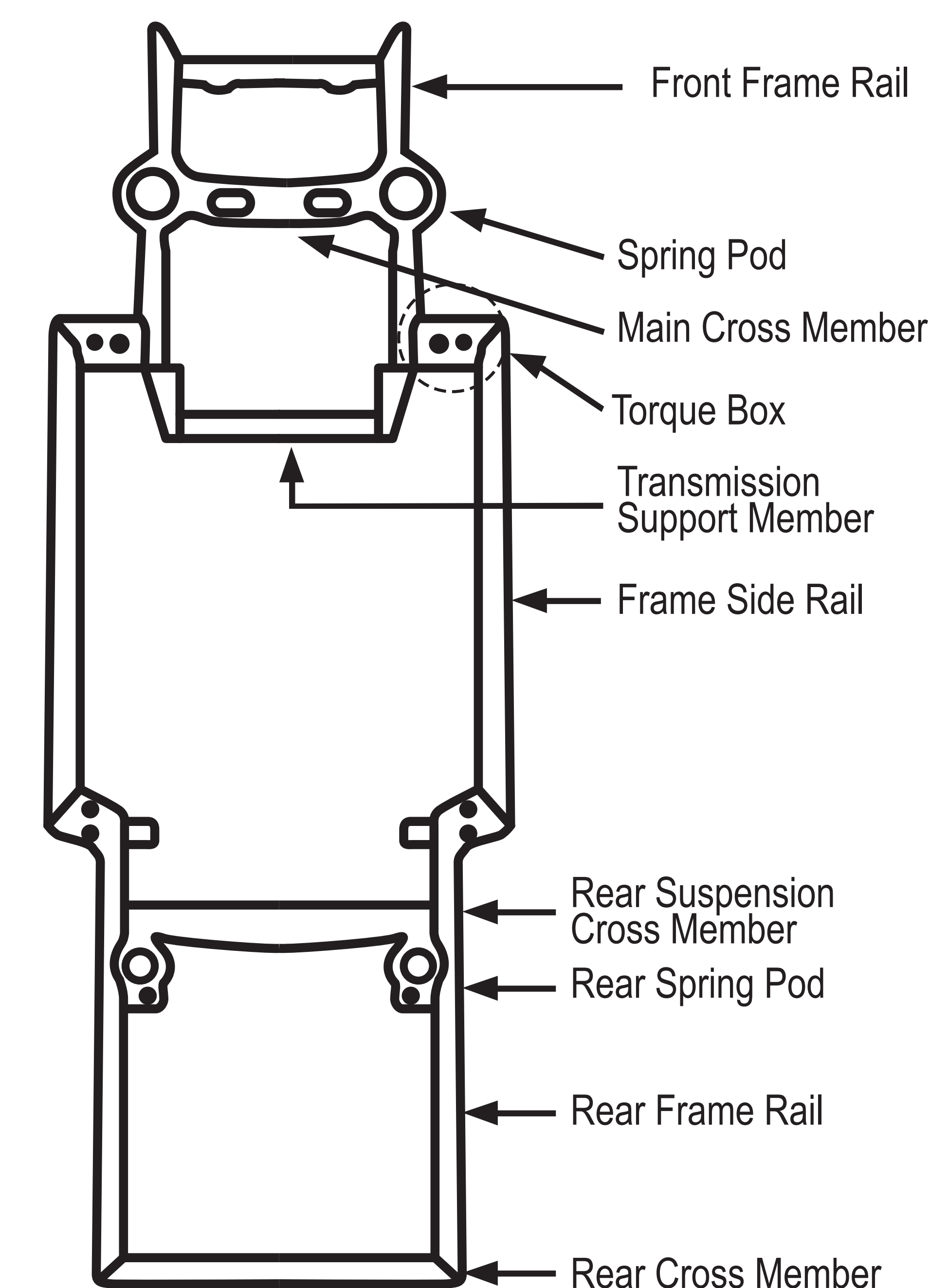

Structural Components

Structural Damage Disclosure Requirement

	Unibody	Unibody on Conventional Structure	Conventional Structure
1. Frame Rails (Including Front, Center and Rear Rails)	Existing Permanent Damage, Removed, Modified, Repaired or Replaced		
2. Spring Pod, Torque Box or Stabilizer Mount	N/A	Existing Permanent Damage, Removed, Modified, Repaired or Replaced	
3. Cross Members (Except Bolt-On)	Existing Permanent Damage, Removed, Modified, Repaired or Replaced		
4. Apron Assembly	Existing Permanent Damage, Removed, Modified, Repaired or Replaced		N/A
5. Strut Tower Assembly	Existing Permanent Damage, Removed, Modified, Repaired or Replaced		N/A
6. Cowl Panel/Firewall	Existing Permanent Damage, Removed, Modified, Repaired or Replaced		N/A
7. Support Pillars (Includes A, B, C*, D)	Existing Permanent Damage, Removed, Modified, Repaired or Replaced		
8. Roof Braces/Bows	Existing Permanent Damage, Removed, Modified, Repaired or Replaced		
9. Rocker Panel (Outer)	Replacement Only		N/A
10. Rocker Panel (Inner)	Existing Permanent Damage, Removed, Modified, Repaired or Replaced		N/A
11. Floor/Trunk Panels	Tears 1" or More, Existing Permanent Damage, Removed, Modified, Repaired or Replaced Panels		N/A
12. Quarter* or Cab* Panel	Replacement Only		N/A
13. Inner Quarter Panel Assembly (Includes Inner Wheelhouse Panel, Rear Strut Tower, and Wheelhouse Extension Lower)	Existing Permanent Damage, Removed, Modified, Repaired or Replaced		N/A

* Only Applies to Components Deemed Structural Per the Vehicle Manufacturer.